

HAZARDOUS WEATHER DETECTION AND DISPLAY CAPABILITY FOR US NAVY SHIPS

Timothy Maese *, Jim Hunziker, Henry Owen and Mike Harven
Basic Commerce and Industries, Moorestown, NJ

Lee Wagner, Richard Wilcox, Kim Koehler and CDR Gerald Cavalieri
SPAWAR Systems Center / PMW-180, San Diego, CA

1. INTRODUCTION

US Navy aviation ships, such as the NIMITZ-class (CVN68) nuclear powered aircraft carriers and amphibious assault ships (LPD-17, LHA-3 class), have missions which inherently rely significantly on the weather conditions around the ship. Tasks ranging from strike planning to flight operations, such as aircraft launch and recovery, require knowledge of the current and future weather conditions to improve operational effectiveness and efficiency, prevent accidents, and provide the greatest advantage possible over an adversary. However, many naval vessels at-sea often lack organic weather radar information that would provide a real-time assessment of the current weather conditions around the ship.

A key tool in providing real-time weather information to shipboard personnel is the Hazardous Weather Detection and Display Capability (HWDDC). HWDDC is an adjunct weather radar processor and web-display server that provides real-time weather radar data and imagery from the Navy's SPS-48E radar system aboard these aviation platform ships. The HWDDC system extracts raw radar returns from the SPS-48E radar, converts them to NEXRAD-like weather measurements, and provides radar products to users on the shipboard network via a simple web-page display. The prototype HWDDC system was installed on the USS PELELIU (LHA5), an amphibious assault ship, for a 6 month at-sea deployment in February 2006. The second HWDDC system is scheduled for installation on the USS NIMITZ (CVN68) in March 2007 and will provide near real-time weather data during the ship's deployment. BCI has developed the processor and web-server for the HWDDC system under

contract to SPAWAR Systems Center – San Diego. The data interface from the SPS-48E radar to the BCI processor was developed by ITT-Gilfillan.

2. HAZARDOUS WEATHER DETECTION AND DISPLAY CAPABILITY SYSTEM

Dedicated weather radars are routinely found near airports around the world, and data from these radars are used by pilots and air traffic controllers for route planning. US Navy ships at sea do not have the luxury of a dedicated weather radar system on their already crowded decks, and they have gone without organic radar capabilities for decades. However, many of the existing air-surveillance radars used on modern warships perform well as meteorological radars, proven in several 'through-the-sensor' data collection experiments and demonstrations.

2.1 'Through-the-sensor' Weather Radar Surveillance

The key benefit of using an existing sensor to provide weather radar data is that the need to develop a new system, install it on a crowded top-side antenna mast, and perform maintenance on additional mechanical and electronic equipment is reduced significantly, if not eliminated entirely. This 'through-the-sensor', or TTS, data collection concept allows the SPS-48E radar to provide weather data while completing its tactical mission without compromise. The through-the-sensor potential is not unique to the SPS-48E radar, however, as it has been demonstrated previously using a shipboard tactical radar, the SPY-1 phased array radar (Maese *et al.*, 2001).

An important requirement of through-the-sensor data collection is that the tactical sensor must not be changed or impede its mission in order to gather routine weather data. The tactical radar's mission is to detect and track air and surface targets, and this mission is vital to the safety of the crew and ship. Interruption of a

* *Corresponding author address:* Timothy Maese, Basic Commerce and Industries, Inc., 304 Harper Drive, Suite 203, Moorestown, NJ 08057; email: tmaese@bcisse.com

search scan or a change to operating parameters could compromise the radar's ability to detect and track potentially hostile targets and in turn, reduce the ship's ability to protect itself from enemy weapons.

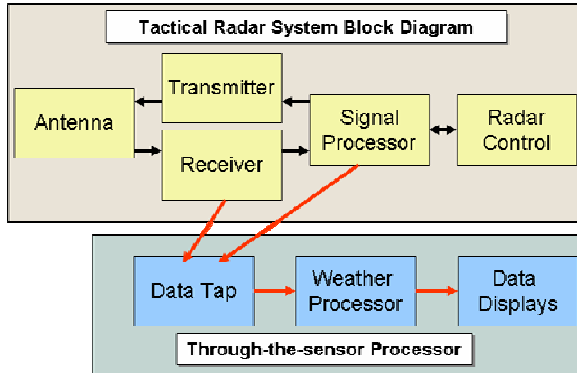

Figure 1: 'Through-the-sensor' Parallel Data Processing Concept

Therefore, the 'through-the-sensor' processing system must, at a minimum, operate using the tactical configuration of the radar, providing weather information with radar scans and parameters (such as pulsewidth, pulse repetition interval, etc.) that were developed to meet a military mission, not a meteorological mission. This challenge imposes some limitations on the data products and the quality of the products developed. However, careful selection of the target radar and processing approach can provide excellent meteorological data with no impact on the radar's tactical mission.

Once the weather data are collected, the final challenge is to distribute and present the data to the appropriate users on-board and off-board the ship in an easily interpreted format. Many Navy ships at sea do not have trained meteorologists onboard, and even those that do (such as the aircraft carriers) have many users onboard that would use the weather radar information but do not possess specific training in meteorology. Thus, data quality control and presentation of products becomes increasingly critical – as the system provides no benefit to the warfighter if the warfighter cannot understand the data quickly and effortlessly.

2.2 Lessons Learned for Dedicated Meteorological Radars

Successful processing of tactical radar data for meteorological surveillance purposes requires that the processing algorithms be adapted for a more rapid tactical radar scan.

The result is often that the TTS scan is a rapid scan, producing weather measurements in a much shorter time than standard meteorological radars. There are lessons to be learned from these TTS assets that can be leveraged for future dedicated National Weather Service (NWS) and Federal Aviation Administration (FAA) meteorological radars.

For example, many tactical radars now use phased array antennas. Sometimes, as in the case of the SPY-1 (Maese *et al.*, 2001), they are fully agile phased array radars. Other times, as in the case of the SPS-48E, they have mechanically rotating radar antennas whose rotation provides azimuthal coverage and whose rapid electronic scan pattern provides elevation coverage. In either case, the phased array agility (either fully or in elevation only) lends itself to the development of a rapid scan capability to produce a full weather picture in a reduced amount of time.

The phased array nature of the SPS-48E is not adequate, alone, to produce a rapid weather scan capability. An adequate number of weather samples must be collected to produce accurate weather measurements. The addition of range averaging provides a mechanism by which larger numbers of samples can be taken within a more rapid weather scan, allowing the radar to produce high quality weather measurements in a short amount of time.

These two characteristics (phased array agility and range averaging of measurements) are common to the two primary Navy shipboard radars that have been used to demonstrate TTS weather surveillance capability. TTS adjunct processors for these two radars (the SPS-48E and the SPY-1) take advantage of these characteristics because they must. However, future NWS and FAA meteorological radars can be designed to have these characteristics to support rapid scan capabilities.

2.3 HWDDC System Description

Although the SPS-48E is a 3-dimensional air surveillance radar intended to detect and track aircraft and missiles, its operating characteristics are well-suited for weather detection. It is an S-band system that scans mechanically in azimuth and scans by transmit frequency selection in elevation. The high-powered transmitter, relatively short pulse length, and reasonable antenna beamwidth provide performance not far removed from many dedicated weather radars, including the WSR-

88D. By processing the radar data collected by this radar through a separate processing chain from the tactical target detection chain, it is possible to extract high-fidelity weather information normally disregarded by the radar as clutter.

The HWDDC system is composed of two subsystems, the Weather Data Interface Card (WDIC) and the Weather Extractor Computer (WEC). The WDIC interface card provides a completely non-interfering data tap within the SPS-48E radar to extract the raw radar returns. The WDIC provides access to the raw radar returns and corresponding information that the SPS-48E equipment provides for processing the returns, such as the azimuth and elevation of the beam, the transmitter power level, and ship's position, course, and speed. The return data are provided from two radar modes; a single pulse transmission and a Moving Target Indicator (MTI) mode analogous to a pulse Doppler train.

The Weather Extractor Computer subsystem accepts the radar data captured by the WDIC, converts the data into spectral moment estimates, and provides a web-based user display. The SPS-48E radar's single pulse returns are converted into reflectivity estimates that cover a range in excess of 277 kilometers (150 nm). The MTI pulse trains are processed using a pulse-pairs algorithm and provide reflectivity, mean radial velocity, and spectrum width estimates. The tactical MTI mode has a limited range extent of about 56 kilometers (30 nm) due to the relatively short pulse repetition interval used in the waveform.

The WEC incorporates several traditional weather radar processing features, as well as some novel algorithms required to make optimal use of tactical radar scans. Point clutter editing, range/velocity unfolding, and surface clutter filtering are employed in the WEC to improve data quality. However, the tactical MTI waveform and scan parameters of the SPS-48E eliminate the possibility of using traditional clutter filters, such as those used in the WSR-88D. Compounding this is the fact that the radar platform is moving and the 'ground' clutter most often comprises returns from the sea surface. In designing the WEC processing algorithms, a different approach to surface clutter filtering was required.

The clutter filtering approach used in the HWDDC processor is similar to several that have been used previously for tactical radars. A number of adaptive MTI algorithms have been

developed which are based on a filtering operation that involves the multiplication of an incoming data sequence with a matrix that acts as a filter. Several of these techniques, applied to tactical radars, are discussed in (Armstrong, 1992). The benefit of these types of matrix filter approaches is that no data are consumed in the filtering operation. Unlike a traditional finite impulse response (FIR) or infinite impulse response (IIR) filter, as many pulses are produced at the output of the clutter filter as are present at the input.

The HWDDC processor leverages previous work done in adaptive MTI processors to implement a clutter filter using a similar matrix multiply operation. The initial implementation of the clutter filtering operation uses fixed filter coefficients. It is expected that more adaptation will be added as more at-sea experience is gained with the HWDDC processor.

One of the novel processing capabilities of the WEC is the recombination of the individual radar returns into a full volume of data. The SPS-48E scan rate is 4 seconds – that is, the radar scans its entire coverage area once every four seconds. In comparison, traditional weather radars, such as the WSR-88D, take several minutes to complete a volume scan. In order to improve the accuracy of the HWDDC data, several consecutive SPS-48E scans are collected and combined in a single reference volume at a fixed position. This requires compensation for ship's motion in the data continuously during processing, not only to align the returns from each scan to a fixed location in space, but to correct for the effect of the motion on the estimated velocity and spectrum width moments.

The HWDDC system is fully automatic – no personnel are required to configure or operate the system. Once powered up, the WEC processor automatically boots into an operational mode and begins data collection and processing of radar data streamed through the WDIC. Every 60 seconds, the WEC provides a full volume of spectral moment data, which are archived for several hours on the system's hard drive. The final output from the WEC is a full spectral moment report, written in Universal Format, along with radar products such as Composite Reflectivity and Velocity Azimuth Display winds written out in NEXRAD format.

2.4 WEC Processing Platform

The Weather Extractor Computer platform uses commercial off-the-shelf hardware

components and open-source non-proprietary software. The processing hardware consists of rack-mount PC servers and runs the LINUX operating system. The processor architecture uses multiple parallel processors in order to complete all data processing in near-real-time. The initial prototype WEC (called WEC version 0) was composed of two rack-mount servers, each with two Intel Xeon CPUs running at 3.8 GHz. This platform is shown in Figure 2.



Figure 2: Weather Extractor Computer (version 0 prototype) Processor

The next WEC system (version 1) will have an increased processing capacity, using four dual-core processors running at 3.0 GHz each. Data are passed from one processor to another via standard gigabit Ethernet (1000 Base-T) ports on each server using the

Message Passing Interface (MPI) data transport protocol. The WEC connects to the data tap within the SPS-48E radar via serial Front Panel Data Port (FPDP), a fiber optic data link that allows the WEC to be located virtually anywhere the cable can reach on the ship.

The web-based displays and interface supported by the WEC server is available on the Navy's classified LAN (SIPRNET) onboard the ship, as well as off-board via satellite connectivity to other ship and land-based SIPRNET clients. In addition, a video converter provides real-time display video, selectable by a Navy METOC operator, over the ship's closed circuit television system (called 23-TV) to allow users in spaces without SIPRNET terminals to see the live radar display.

To prevent system failure or corruption due to a temporary power loss, the system includes an uninterruptible power supply that enables the system to remain operational for 15 minutes in the event of a loss of power. The HWDDC is automatically shut down before this time expires to prevent corruption or damage to the file system due to an improper operating system shutdown. The use of a journaling file system also supports this protection.

2.5 HWDDC Data Products

The HWDDC system provides both raw

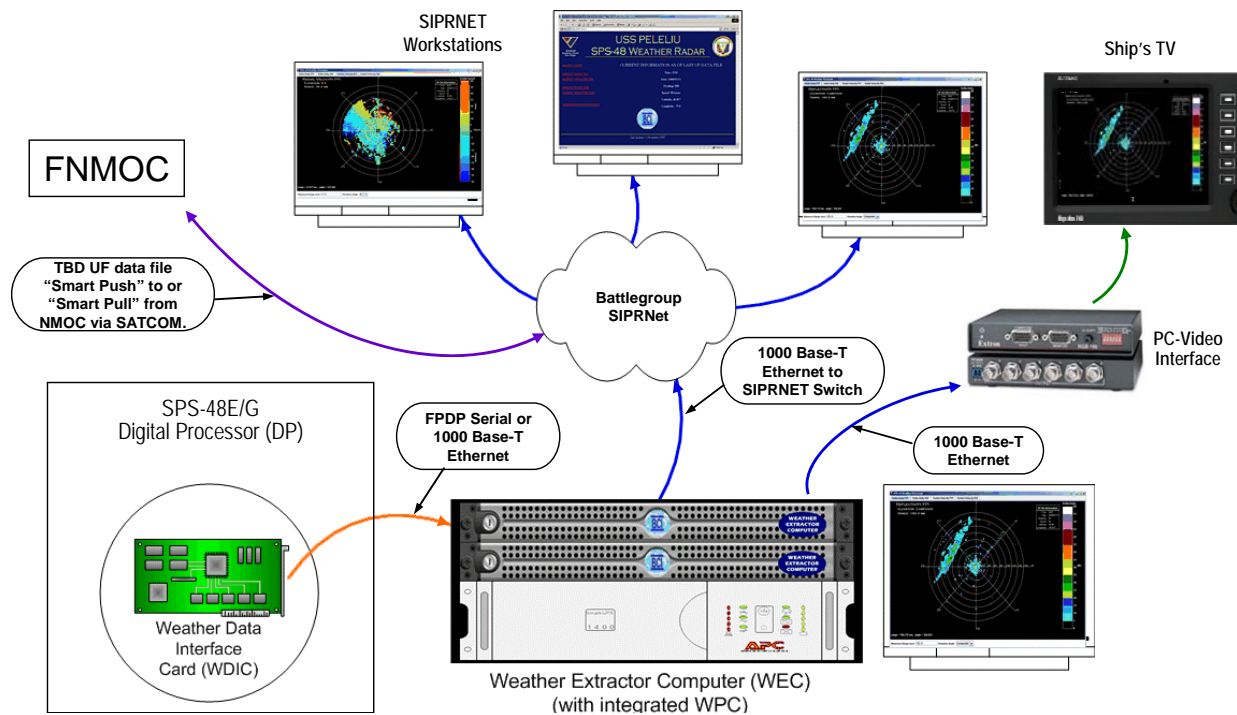

Figure 3: HWDDC System Block Diagram

spectral moment output and derived data products, as shown in Table 1. The WEC processor generates standard spectral moment estimates (reflectivity, radial velocity, and spectrum width) and writes these estimates to disk in Universal Format (UF). Two derived products, composite reflectivity and Velocity Azimuth Display (VAD), are included in the version 1 system and are written in NIDS product format. Future versions of the WEC processor are planned to write additional data products including, but not limited to, echo top heights and vertically integrated liquid.

Several data quality control measures are included in the version 1 system. A custom surface clutter filtering algorithm is applied to the pulse Doppler sequences received from the radar to help attenuate the returns from close-in sea surface clutter and landmasses. A point clutter editing function removes returns from aircraft and ships. The spectral moment processing also performs range foldover identification and removal, as well as dealiasing of the radial velocity estimates.

SPECTRAL MOMENT ESTIMATES
Reflectivity (dBZ)
Mean Radial Velocity (m/s)
Spectrum Width (m/s)
DERIVED RADAR PRODUCTS (NEXRAD FORMAT)
Composite Reflectivity (dBZ)
Velocity Azimuth Display wind field
Echotop Heights (planned)
Vertically Integrated Liquid (planned)
DATA QUALITY CONTROL ALGORITHMS
Range Unfolding
Velocity Unfolding
Point Target Editing
Surface Clutter Filtering

Table 1: Current and Planned HWDDC Data Products

3. AT-SEA TESTING RESULTS

The version 0 HWDDC system underwent land-based system testing during January 2006 at the Navy's SPS-48E test site in Dam Neck, VA. During this testing, the spectral moment outputs were compared to the Wakefield/Norfolk-Richmond, Virginia WSR-88D NEXRAD radar. This comparison showed a very close qualitative match between the output of the HWDDC system and the NEXRAD radar. A composite reflectivity plot from the land-based testing events is presented in Figure 4. Note

that the surface clutter filter and point clutter editing functions were not enabled during this test.

In February of 2006, the version 0 HWDDC system was installed on the USS PELELIU (LHA5). The system deployed with the ship for its entire 6-month operational tour. In the first 20 days after leaving port, the HWDDC system provided the Navy and Marine Corps personnel the capability to continue flight operations of Harrier jets and helicopters that normally would have been cancelled due to poor weather. On three separate occasions in these first three weeks, the ship was steered around non-flyable weather cells and into clear areas so that the ship could resume flight operations. This provides a considerable time and resource savings for the Navy and Marine Corps and enhances their operational safety and efficiency.

A composite reflectivity image from the PELELIU while off the coast of Hawaii is shown in Figure 5.

4. FUTURE PLANS

The version 1 HWDDC system is currently in development and is planned to be deployed with the USS NIMITZ (CVN68), a nuclear-powered aircraft carrier, in April 2007. This system will have several enhancements such as clutter filtering, an improved geo-referenced display, and several additional data quality control improvements and data products.

5. ACKNOWLEDGEMENTS

The HWDDC effort could not have been completed without the dedication and sponsorship of the Program Executive Office – C4I and Space (PMW-180). The authors thank Mr. Thomas Piwowar, and CAPT Mike Huff for sponsoring the HWDDC version 0 and version 1 efforts. In addition, the authors thank our colleagues at the Naval Surface Warfare Center – Virginia Beach, and in particular Will Lawson, for their support and hospitality during land-based testing of the HWDDC version 0 system. Finally, the authors thank the commanding officer and crew of the USS PELELIU, and the commander of Expeditionary Strike Group-3, USMC BGEN Carl Jensen.

6. REFERENCES

Maese, T., J. Melody, S. Katz, M. Olster, W. Sabin, A. Freedman, and H. Owen, 2001: Dual-use Shipborne Phased Array Radar Technology and Tactical Environmental

Sensing, *Proceedings of the 2001 IEEE Radar Conference*.

- B. C. Armstrong, 1992: A Comparison of Conventional, Adaptive and Hybrid Doppler Processing Techniques, *Proceedings of the*

1992 *South African Symposium on Communications and Signal Processing*, pp. 127-134.

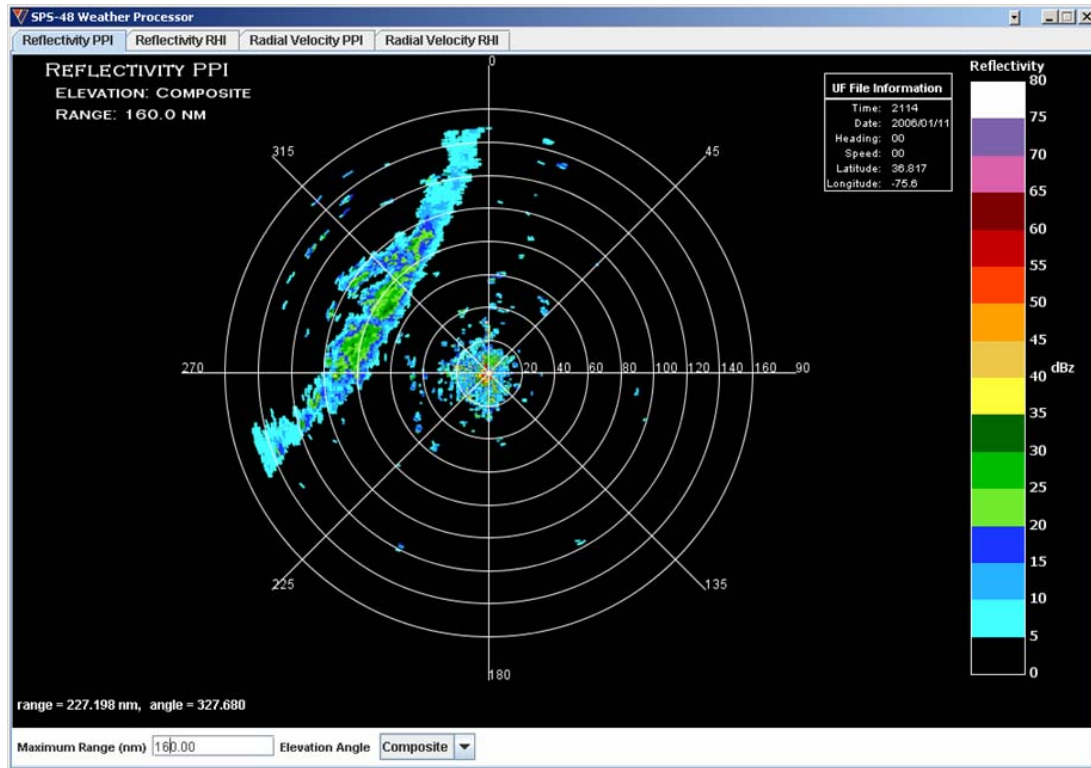

Figure 4: Composite Reflectivity PPI Displaying an Approaching Storm Front During Land-based System Testing at Dam Neck, VA on January 11, 2006

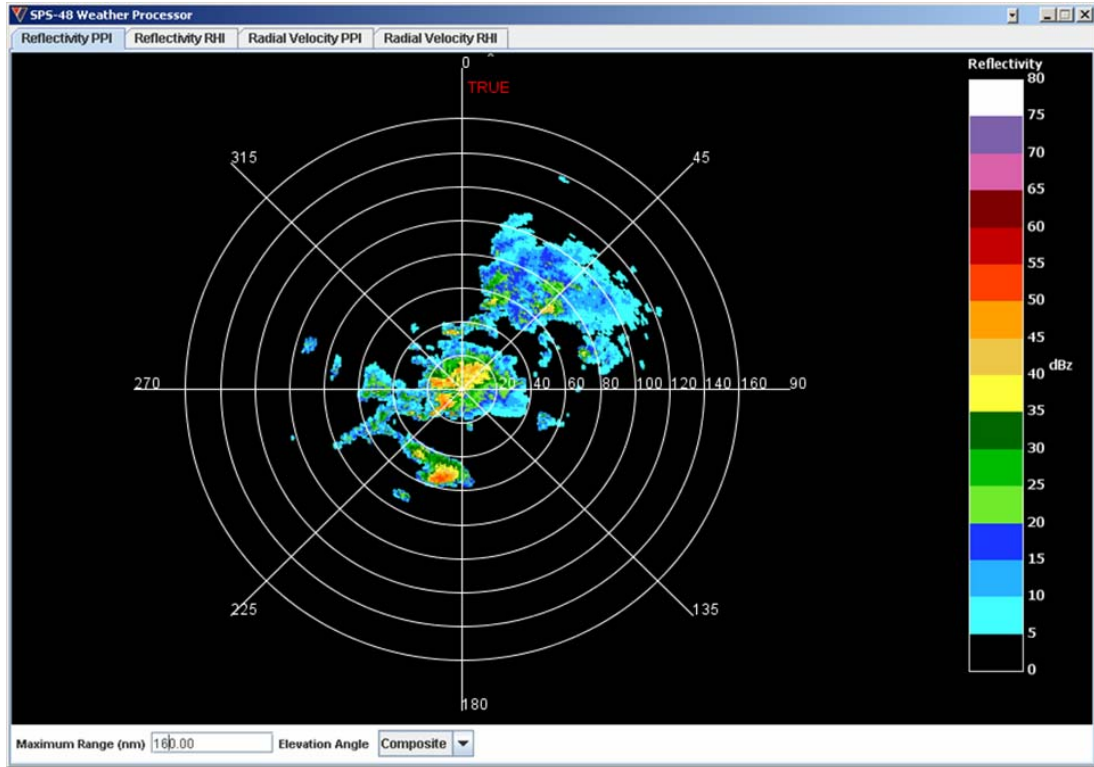

Figure 5: Composite Reflectivity PPI Displaying Weather from the USS PELELIU off the Hawaiian Islands on February 23, 2006