

# Development of All-fiber coherent Doppler LIDAR system for wind sensing

Sameh Abdelazim, David Santoro, Mark Arend, Fred Moshary, Sam Ahmed  
Electrical Engineering Department, City College of New York, New York, NY 10031, USA

**Abstract:** Coherent Doppler LIDAR is being utilized to develop a mobile wind speed measuring station. We are building an all fiber based eye safe laser system to measure wind speed in urban areas. A 1.5 $\mu$ .m polarization maintained fiber optics master oscillator power amplifier system is used, which utilizes inexpensive telecommunication components. A heterodyne balanced detection is being used to suppress the RIN noise. We have calculated the optimum local oscillator power for maximum optical detector's efficiency. Analog to digital conversion (ADC) will be performed at 400 MHZ by using a data acquisition card with FPGA on board, which can be programmed to perform autocorrelation and/or FFT onboard for faster performance. This system can be used along with other units on top of high buildings in New York City as a way of detecting wind speed profile for Homeland security.

## Introduction

The Coherent Doppler Lidar (CDL) is suitable for atmospheric measurements such as wind speed and aerosols' concentration [1]. Fiber based systems based around C-band telecommunications components has become a popular because of the ease in obtaining components and the potential for hardened systems that can operate in an eye safe mode autonomously

[2,3,4]. The technique uses heterodyne detection by mixing the received laser signal (scattered by aerosols) with a local oscillator signal. The output of the photo detector is an RF signal containing information about the wind speed and aerosol concentration at various ranges.

## SYSTEM OVERVIEW

The system consists of the following components:

1) Laser source 2) Modulator 3) Fiber Amplifier 4) Optical Antenna 5) Detector 6) Signal Processor as shown in figure 1. In our system, a fiber coupled 1545.2 nm laser is used for the master oscillator. This source is split using a fiber coupler. One signal is used as a local oscillator (LO), while the other signal is modulated and frequency shifted using an AOM (acousto-optic modulator). The modulated signal is then amplified and transmitted through an optical antenna. The scattered signal will be received by the optical antenna and mixed with the LO signal through a 50/50 coupler. The mixed signal will be detected by a balanced detector, which generates a RF electrical signal. The RF signal is then processed using a signal processor to extract information about frequency shift and signal strength as a function of time delay.

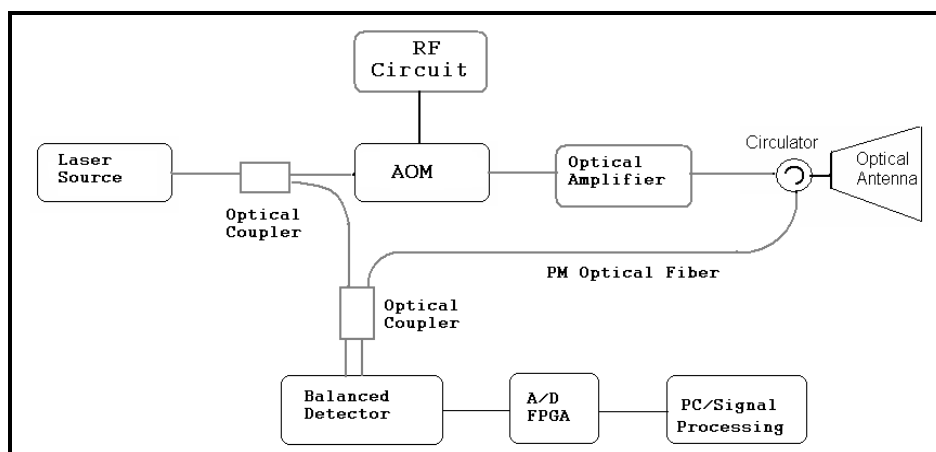

Fig. 1 Coherent Doppler Lidar system's configuration

## Laser Power Analysis:

In order to determine the optimum local oscillator power level, the following analysis was done:

By increasing local oscillator power (PL), shot noise from local oscillator will dominate thermal noise on load impedance (RL). Low level of PL will cause thermal noise to dominate shot noise, and optical efficiency will suffer as shown in fig. 2. RIN noise can be reduced by a factor of RB (RIN suppression ratio.) through the use of a balanced detection. Heterodyne detection general formula that relates the local oscillator power to power efficiency is give by the following equation [2]:

$$\eta_{pp} = \left[ \frac{\eta_q P_L R_{in} R_B}{2h\nu} + \frac{2kTF_N h\nu}{\eta_q e^2 P_L R_L} + 1 \right]^{-1} \quad (1)$$

- $\eta_{pp}$ : Efficiency on power penalty
- $\eta_q$ : Quantum efficiency of the detector
- k: Boltzmann's constant
- $R_B$ : Balanced detection suppression
- h: Plank's constant
- $R_L$ : Load resistor
- e: Electron charge
- T: Temperature in degrees Kelvin

Assuming room temperature operation, a 70 Ohm load resistor, and 0.8 quantum efficiency, the efficiency on power penalty can be plotted as a function of local oscillator power for  $R_{in}$  values of between -140 dB/Hz and -170dB/Hz as shown in Fig. 2. As RIN is frequency dependent, we requested that the RIN to be measured vs. frequency in the band of interest to us (50 to 110 MHz.) Fig. 3 shows that the measured  $R_{in}$  is less than -152 dBm/Hz in band. Therefore, operating with about 12 dBm of LO power on each detector of our balanced detector units should be optimum and provide us with a few dB of margin in available power. Based on our analysis, we should be able to detect signals 20 db lower than the shot noise. Recent reports of field operations of similar systems [5,6] have inspired our development and suggested our improvements to take advantage of signal enhancements by using balanced detection as well as advanced signal processing.

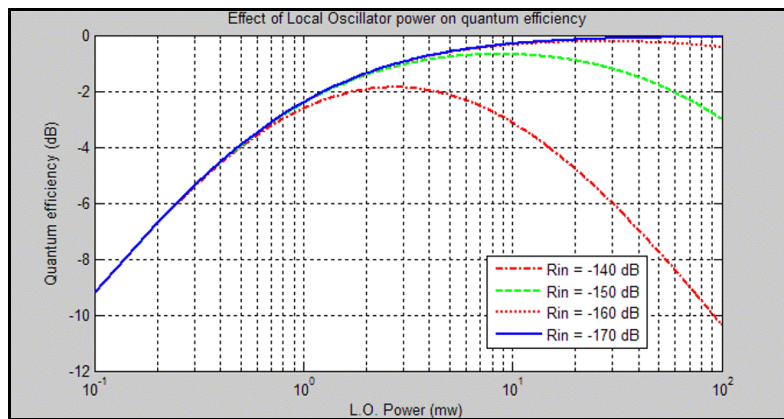

Fig. 2 Effect of Local Oscillator Power on Efficiency Power Penalty

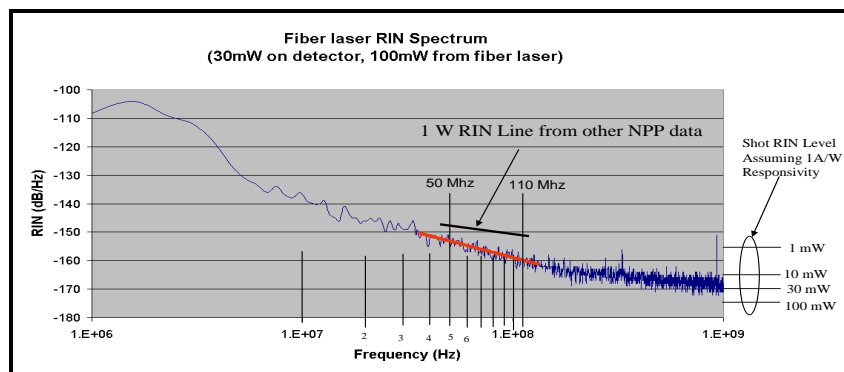

Fig. 3 Relative Intensity Noise Vs. Frequency

## Setup Procedure to Observe Scattered Signal:

To assure the fiber's optimum alignment with the lens' focal point, the experimental setup shown in fig.4 was used. The laser pulses were shot at a hard target (~ 100m), and the scattered signal was obtained and monitored on the oscilloscope. Figure 5 shows the scattered signal off a hard object in time domain.

Maximizing the magnitude of the hard target's scattered signal through adjusting fiber's x,y, and z positions achieves the optimum fiber's location to focus the beam at about 100 m (hard target's distance). To focus the beam at a different distance, the z position of the fiber holder can be adjusted accordingly. We then direct the laser beam to the atmosphere, and obtain the atmospheric scattered signal as shown in figure 6.

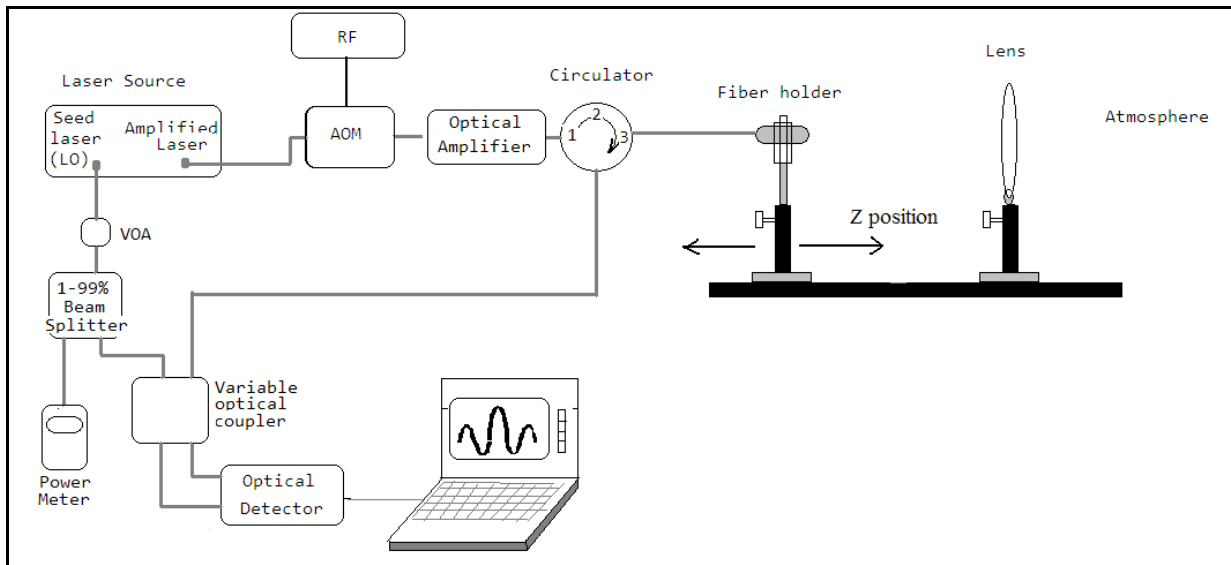

Fig. 4 Set up procedure to observe scattered signal

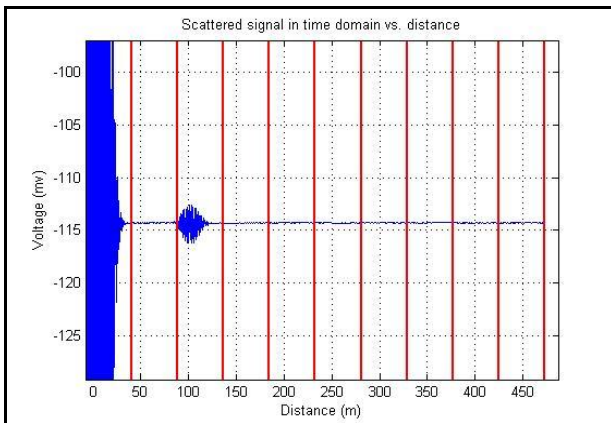

Fig. 5 Time domain scattered signal off a hard target

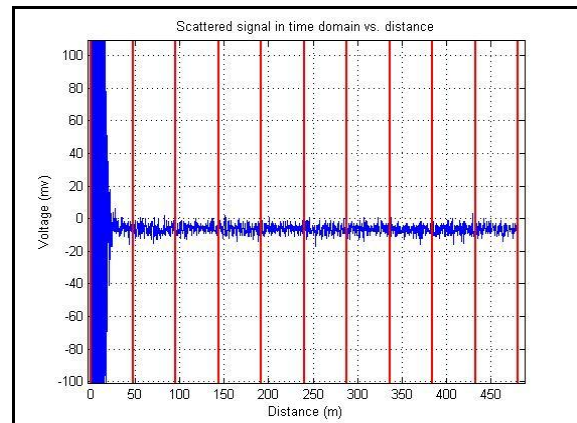

Fig. 6 Time domain scattered signal off the atmosphere

## Signal Processing:

In order to achieve a high speed Doppler signal processing, an analog to digital board is being used, which runs at 400 MHz with FPGA (Field Programmable Gate Array) on-board. The FPGA will be programmed to calculate FFT, which will be averaged from pulse to pulse. The modulator is triggered at 20 kHz and gated for 200 ns pulses, which results in a range resolution of ~30m. We are aiming to reach a range of 2-5 km. The scattered signal is divided into different range gates. According to the

number of data samples per gate, the bandwidth resolution will be set. FFT of each gate is being calculated and averaged over different pulses resulting in the power spectrum, which shows wind speed at that gate. Figure 7 shows the power spectrum of the gate where the hard target occurred. Figure 8 shows the FFT of atmospheric scattered signal at gate three, which expands from 100m to 150 m. The power spectrum shows a peak at 87.5 MHz. Wind speed can now be calculated, as it is proportional to the frequency shift of the scattered signal i.e. the difference between 87.5 MHz and 84 MHz

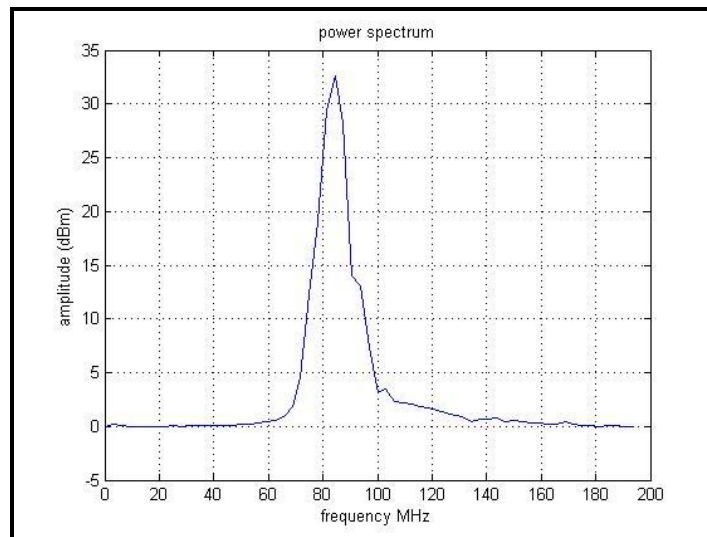

Fig. 7 Scattered signal FFT of first range gate (where the hard target occurred)

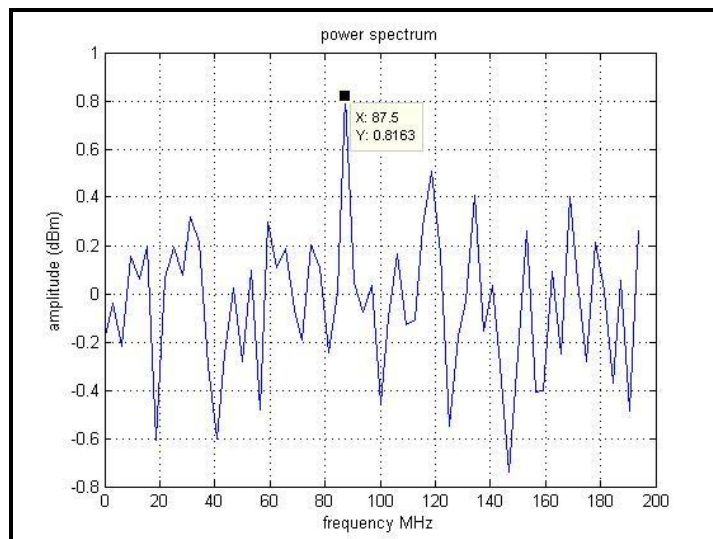

Fig. 8 Scattered signal FFT of gate 3 (100m ~ 150m) range

## References:

1. R. M. Huffaker and R. M. Hardesty, "Remote sensing of atmospheric wind velocities using solid-state and CO<sub>2</sub> coherent laser systems," *Proc. IEEE* **84**, 181–204 (1996).
2. S. Kameyama, T. Ando, K. Asaka, Y. Hirano, and S. Wadaka "Compact all-fiber pulsed coherent Doppler lidar system for wind sensing", *Applied Optics*, 46, 1953-1962 (2007)
3. Kameyama S., et al.: *Proc. of 11th Coherent Laser Radar Conference, CLRC*, 76-80, 2001.
4. Jean-Pierre C., Beatrice A, Matthieu V., "Laser Source requirements for coherent lidars based on fiber technology", *C. R. Physique* 7 (2006) 213–223
5. T Ando, S Kameyama, Y Hirano, "All-fiber Coherent Doppler LIDAR technologies at Mitsubishi Electric Corporation", 14th International Symposium for the Advancement of Boundary Layer Remote Sensing, *IOP Conf. Series: Earth and Environmental Science* **1** (2008) 012011
6. J. P. Cariou, L. Sauvage, S. Lolli, R. Parmentier, M. Boquet, and S. Loaec "Planetary Boundary Layer dynamic measurements with new compact long range wind Lidar Windcube™ WLS70", Fourth Symposium on Lidar Atmospheric Applications, 89th American Meteorological Society Annual Meeting (Phoenix, AZ), 2009